

Smart Card Based Digitalization Of India Using IOT

#¹Snehal Anandrao Patil, #²Meera Rajendra Khandagale, #³Renuka Arunrao Unche
#⁴Shubham Manoj Hivare, #⁵Prof.Rajani Thite



¹snehalpatil27jully@gmail.com
²meerakhandagale456@gmail.com
³renukaunche22@gmail.com
⁴shubhamhivare05@gmail.com
⁵rajani.thite@dyptc.edu.in

#¹²³⁴⁵Department of Information Technology
Dr.D.Y.Patil College of Engineering, Ambi, Pune.

ABSTRACT

Smart cards are adopted by people all over the world for various applications. They are only intra Domain due to safety and reliability concern. There has been soaring demand for secure system that must be dependable and quick respond for the industries and company. RFID (Radio Frequency Identification) is one of the uniform and fast means to a technology whereby digital data encoded in RFID tags are acquisition by reader via radio waves. Using this technology we can establish secure and intermodal approach towards creating a multipurpose smart card. According to literature survey, there is no research proposal to describe that one smart card to support many application domain invariability. In this system we are going to integrate cards like Driving Licence, PAN card, ADHAR card, Ration card into single card. By using AES(Advanced Integrated Standard) algorithm the security inspection ensures that smart card provides strong security for multipurpose smart card implementation. For the security and authentication purpose the OTP(One Time Password) will be sent to the card holder and further process will be proceed for document verification at the server.

Keywords: RFID Card, Reader, Controller, Digitalization.

ARTICLE INFO

Article History

Received: 26th May 2019

Received in revised form :
26th May 2019

Accepted: 28th May 2019

Published online :

29th May 2019

I. INTRODUCTION

RADIO FREQUENCY IDENTIFICATION (RFID):

This paper provides knowledge on radio frequency identification (RFID) technology. Initially RFID tags were made to eventually replace barcodes in different chains. Their advantages are that they can be read wirelessly and with no line of sight, contain more data than barcodes, and are stronger. As the paper describes the recent technology, include the frequency ranges used and standards required. With the increase in ubiquity of RFID tags, however, privacy became unease. The paper outlines probable attack that can go against one's privacy and it also describes contradict measures. The RFID technology did not stop at thing-level tagging. The paper also presents current research that focuses on locating and tracking labeled object that move. Since the uses for RFID tags are so extensive, there is a large interest in lowering the costs for production of RFID tags. It turns out that printing tags may become a possible alternative to traditional production.

RFID tags or simply "tags" are small transponders that respond to queries from a reader by wirelessly transmitting a serial number or alike identifier. They are greatly used to track items in production environment and to label items in supermarkets. They are usually thought of as a highly developed barcode.

However, their possible region of use is much bigger. This paper presents applications that are probable using RFID technology such as locate access control, location tracking, billing easily and others. RFID tags are expected to multiply into the billions over the coming few years and yet, they are been treated the same way as barcodes without taking into consideration the impact that this advanced technology has on privacy.



Fig 1. RFID card and Reader

II. PROBLEM STATEMENT

To defeat the problem of showing any card at particular office, by developing a system to validate the document of the particular user whose information is stored in the data base, which saves time and scale down inconvenience.

III. LITERATURE REVIEW

(Chopra, Ghadge, Padwal, Punjabi, & Gurjar, 2014) explained that There can be improvements made when the image is captured using a camera, as it decreases the resolution factor of the images and thus, degrade their quality. The project can be extended for recognition of handwritten characters as well as its application in various fields of recognition of diverse cards. Thus, the system has achieved the clarification for automatic reading of Aadhar Card with a good accuracy.

(Deepu & Dr. Vijay Singh, 2012)(Knowlton & Whittemore, 2008) suggested that the government will use the information to issue identity cards the word which is generally known as AADHAR CARD. (Tiwari, 2013)described that the user logs in to the account using his aadhar card number and the password provided him at the time of registration and giving vote.

(Shah & Shah, 2014)(Goel & Singh, 2014) described that National Bureau of Investigation in Philippines, India's most recent Aadhaar card includes QR code implementation. Based on the all information we should consider the government consider only one card for the identity card of the person as Aadhaar card which is also helpful to provide the different government activities like to take subsidy and also take advantages of the different governments' scheme.

(Kale & E, 2014) told that the growth in the electronic transaction scheme has resulted in a greater demand for accurate & fast user identification and authentication. An embedded fingerprint biometric authentication scheme for ATM banking systems is proposed in this paper. Along with AADHAARCARD authentication for more security.

(Akhil Mittal, Anish Bhart, Sanjoy Sahoo, Tapan K Giri, 2011) suggested that Aadhar Card is unique for person which have person's finger print and retina scan. It can used to identify person anywhere in the country. (Velapure et al., 2015)(Velapure et al., 2015) found that the distinctiveness with registration through aadhar number and face recognition will offer very strong security for the secret information about vote.

(Gupta & Dhyani, 2013)found that e- Voting model has been integrated with AADHAR CARD or Unique Identification (UID) card data base using cloud. By integrating e-Voting model with cloud infrastructure and ADHAAR CARD record, percentage of polling would raise and can supply authentic electoral voting mechanism to satisfy the need of the voters.

IV. PROPOSED MODEL

Flow Chart of the Proposed System:

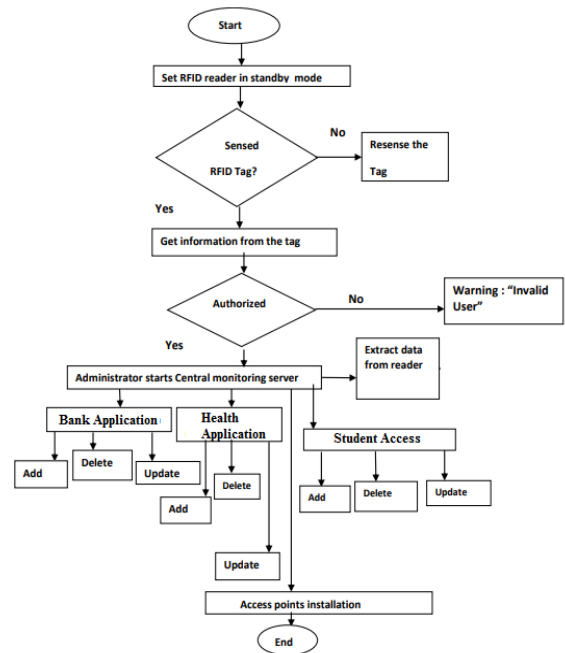

The granular details and specifications will be explained. And we also explain the flow of the system using algorithm.

- (1) Start.
- (2) Centralized server running.
- (3) RFID reader is waiting to get a tag.
- (4) Data simultaneously send to the controller.
- (5) Authentication process identification
- (7) All documents check from the database server
- (7) Display the customer ID on LCD.
- (8) The authentication will be automatically success from the user card.
If (card is not valid)
Authentication failure;
Else
Card is valid;
- (9) After success of the system maintain the users log.
- (10) End.

Module (user)

Login
Registration
Data Base server
RFID Tag
RFID Reader

System (admin)

User Record Maintain
Authentication Module
Unique record fetch
Tag Identification

V. SYSTEM SPECIFICATION

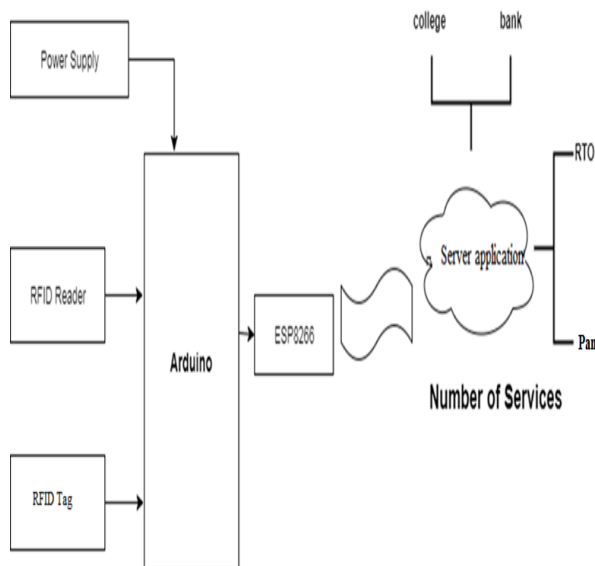

Controller:

A microcontroller is a small and low-cost computer built for the purpose of dealing with specific tasks, such as displaying information in a microwave LED or receiving information from a television's remote control. Microcontrollers are mainly used in products that require a degree of control to be exerted by the user.

RFID Reader:

An RFID reader's function is to interrogate RFID tags. The means of interrogation is wireless and because the distance is relatively short; line of sight between the reader and tags is not necessary. A reader contains an RF module, which acts as both a transmitter and receiver of radio frequency signals.

RFID Tag:

RFID tagging is an ID system that uses small radio frequency identification devices for identification and tracking purposes. An RFID tagging system includes the tag itself, a read/write device, and a host system application for data collection, processing, and transmission.

APPLICATIONS:

The entire project idea is to develop safe and secure system to access the documents using OTP:

- Banks: To open an account and to apply for loans
- RTO : To apply for license and RC
- College : For admission
- Passport office: For verification purpose.

ADVANTAGES:

- The Digitalization provides more reliable backup of documents.
- No need of carrying documents all the time
- The Digitalization will provide less time consuming in government processes
- The system is eco friendly

- The system provides more security due to OTP access for authentication.

VI. CONCLUSION

This proposed system can be implemented with a single RFID card to the all government services. From this implementation this proposed system successfully to store data in the server interface with smart card with small size compare to unique number method. The requirement of this implementation is how to manage the unique id key or each identity in the server. This allows for the secure and a protected way of viewing individual documents.

VII.ACKNOWLEDGMENTS

I wish to express my profound thanks to all who helped us directly or indirectly in making this paper. Finally I wish to thank to all our friends and well-wishers who supported us in completing this paper successfully I am especially grateful to our guide Prof.Rajani Thite for time to time, very much needed, valuable guidance. Without the full support and cheerful encouragement of my guide, the paper would not have been completed on time.

REFERENCES

- [1] Aamir Nizam Ansari , Mohamed Sedkyl, Neelam Sharma and Anurag Tyagil Faculty of Computing, Engineering " RFID-Based Students Attendance Management System" Vol 2, Issue 7, July 2015.
- [2] G.Lakshmi Priya1, M.Pandimadevi, G.Ramu Priya1, and P.Ramya., " Face Recognition Based Attendance International Journal of Engineering and Techniques - Volume 2 Issue 3, May – June 2016 ISSN: 2395-1303 <http://www.ijetjournal.org> Page 32 Marking System", in Architecting the Internet of Things, Berlin, Germany: Springer-Verlag Vol 4, Issue 5, pp 38-43,jan 2011.
- [3] ehun-wei Tseng et.al Department of Infonnation Management Cheng Shiu University Kaohsiung County, Taiwan Design and Implementation of a RFID-based Authentication System by Using Keystroke Dynamics.
- [4] Andrey Larchikov, Sergey Panasenko, Alexander V. Pimenov, Petr Timofeev ANCU D Ltd. Moscow, Russia Combining RFID-Based Physical Access Control Systems with Digital Signature Systems to Increase Their Security.
- [5] M. Vazquez-Briseno, F. I. Hirata, J. de Dios Sanchez-Lopes, E. Jimenez-Garcia, C. Navarro-Cota and J. I. Nieto-Hipolito. Using RFID/NFC and QR-Code in Mobile Phones to Link the Physical and the Digital World, Interactive Multimedia, Dr. Ioannis Deliyannis (Ed.), ISBN: 978-953-51-0224-3, InTech, 2012.
- [6] P. Solic, J. Radić, N. Rozic. Software defined radio based implementation of RFID tag in next generation mobiles, IEEE Transactions on Consumer Electronics, vol. 58, no. 3, pp. 1051-1055, August 2012.
- [7] A. Juels, R. Pappu, B. Parno. Unidirectional Key Distribution Across Time and Space with Applications to

RFID Security, Cryptology ePrint Archive: Report 2008/044.
Available at <http://eprint.iacr.org/2008/044>, 2008.

[8] T. Hollstein, M. Glesner, U. Waldmann, H. Birkholz, K. Sohr. Security challenges for RFID key applications, RFID SysTech 2007, 3rd European Workshop on RFID Systems and Technologies. June, 12-13, 2007, Duisburg, Germany. Proceedings (CD-ROM), 12 pp.

[9] Corporate Information and Personal Data Leakage in 2012. InfoWatch Analytic Report (In Russian). Information Security, #3, 2013.